

Introduction

Artificial time series of weather data offer an attractive alternative to actual data for studies which require long records of daily weather at specific sites. Models have been developed for the generation and estimation of representative weather data via location specific parameters. Such models can be implemented both as stand alone applications (e.g. WGEN) and as integrated applications in a suite to simulate cropping systems models (e.g. CropSyst/ClimGen). However, the lack of specifically-designed libraries makes necessary the implementation of the generation/estimation procedures from the ground every time provisions to produce weather data are required within new software tools. Moreover, it is not possible to mix and match different approaches for weather variables estimate. To overcome the limitations listed above, we developed a software component that incorporates a collection of methods for weather generation/estimation.

Methods

CLIMA contains routines to produce synthetic values of the most relevant weather variables from existing daily data, implementing a collection of approaches. Values of air max/min temperature, precipitation, and wind speed are generated from stochastic processes based on parameters estimated either on daily data or monthly means. Synthetic values of vapour pressure deficit and reference evapotranspiration are produced by physically-based relationships. Solar radiation can be either generated using stochastic or physically-based approaches.

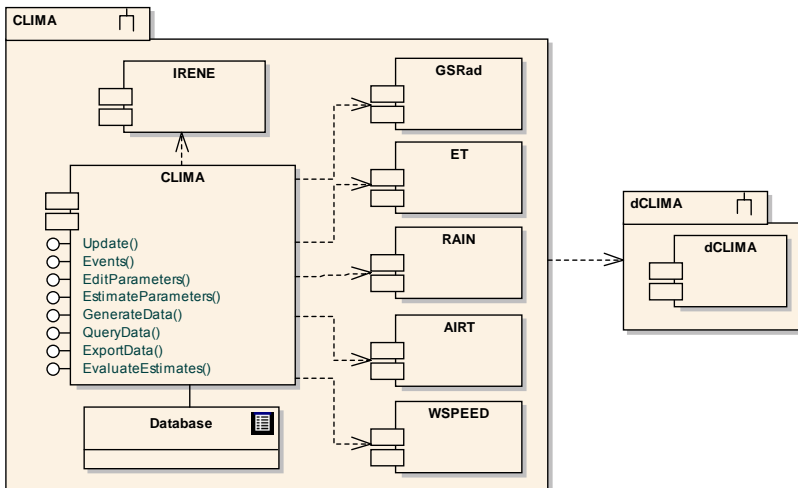

CLIMA is designed using the Unified Modelling Language (UML) notation to describe the products of an object-oriented analysis.

The figure shows the UML component diagram. **CLIMA** exposes the common interfaces required by the SIPEAA system and other interfaces which allow: data generation, query, export, and estimates evaluation vs. measured data. The structure of **CLIMA** is based on sub-components, to allow replaceability within **CLIMA** and reuse outside **CLIMA**. Each of the sub-components is meant to offer for selecting alternative methods to perform estimates and data generation. All sub-components have a public interface for possible use outside **CLIMA**. **CLIMA** and its sub-components are being made available for Windows users as COM or .NET components. A Java version is also being implemented to run also on Linux systems.

The model sub-components implement several options to estimate variables, and they are:

- ▶ **GSRAD** to estimate global solar radiation (hourly/daily values of GSR, extraterrestrial SR, day length, slope and aspect values)
- ▶ **ET** to estimate reference evapotranspiration and vapour pressure deficit
- ▶ **AIRT** to generate air temperature (hourly/daily max-min temperatures)
- ▶ **WSPEED** to generate wind speed (hourly/daily values of wind speed)
- ▶ **RAIN** to generate precipitation (half-hourly/daily values of precipitation, duration, peak value)

Another sub-component, **IRENE**, is a statistical solver whose responsibility is computation of elementary statistics and comparison between actual and synthetic data. The component **dCLIMA** is a data-type which allows instantiating objects which contain weather data to be made available at run time. The **dCLIMA** data-type is implemented as an external component to **CLIMA** to avoid a dependency to **CLIMA** in other components which could use this data-type. The diagram also depicts a database which contains site parameters and actual/synthetic weather data.

Remarks

CLIMA is part of a large action towards the establishment of a configurable component-based architecture and development method for applications in which functions, execution environment and data representation are kept separate. Our primary goal was to develop a design which allows implementing easily new approaches to generate synthetic weather, as they become available from research. Also, our working experience in the area of modelling has suggested to make available sub-components to be used for specific tasks in newly developed software.

CLIMA can be easily implemented in a variety of applications, allowing developers to build object-oriented, cross-language software within both Windows (COM or .NET based) and Linux platforms. The present configuration of the weather generator is currently under testing. The installation packages (whole **CLIMA** and single sub-components) are being made available to non-profit users through the site <http://www.sipeaa.it/software>.